

# International Journal of Advanced Smart Convergence

■ Telecommunication Information Technology (TIT) CPC: A File I/O Cache Management Policy for Compute-Bound Workloads / 01	Hyokyung Bahn
Autonomous Vehicles as Safety and Security Agents in Real-Life Environments / 07	Ahmed Abdulhakim Al-Absi*
■ Human-Machine Interaction Technology (HIT) Joint Demosaicing and Super-resolution of Color Filter Array Image based on Deep Image Prior Network / 13	Edwin Kurniawan† and Suk-Ho Lee††
Fundamental Function Design of Real-Time Unmanned Monitoring System Applying YOLOv5s on NVIDIA TX2TM AI Edge Computing Platform / 22	SI HYUN LEE
Prediction of changes in fine dust concentration using LSTM model / 30	Gi-Seok Lee*, Sang-Hyun Lee**
A study of creative human judgment through the application of machine learning algorithms and feature selection algorithms / 38	Yong Jun Kim*, Jung Min Park**
■ Nano Information Technology (NIT) An Integrated Model for Investigating the Impacts of Telepresence on Cultural Heritage Attachment in Virtual Museum / 44	Kyung-Wan Hong, Ph.D.1, Hyeon-Cheol Kim, Ph.D.2†
W-band Frequency Synthesizer Development Based on Interposer Technology Using MMIC Chip Design and Fabrication Results / 53	Wansik Kim, Hwanyong Yeo, Juyoung Lee, Young-Gon Kim, Mihui Seo, Sosu Kim
Study of Implementation of Broadband Antireflection Coating for Luminescent Solar Concentrators to Optimized the Efficiency / 59	Song Ngo Duy
■ Culture Information Technology (CIT) Comparison of the Characteristics of Green Screen and LED Wall in Virtual Production System / 64	Xinyi Shan1, Jeanhun Chung*
A study on the applicability of interactive technology in VR video content production / 71	Miaoyihai Liu1, Jeanhun Chung*
Research of Character Design in Side-scrolling Horror Puzzle Games / 77	Qi Yi, Jeanhun Chung*
Research of popular success factors of game content <Genshin Impact> / 83	Miaoyihai Liu1, Jeanhun Chung*
A study on the expansibility of sound-responsive visual art contents / 88	Qianqian Jiang1, Jean-Hun Chung2
A Study on Influencer Food-Content Sentiment Keyword Analysis using Semantic Network based on Social Network / 95	Gi-Hwan Ryu*, Chaelin Yu**, Jun Young Lee***, Seok-Jae Moon****
Smart Home Systems for Safety and Security and Individuals' Motivational Orientation to Prevention / 102	Heayon Cho1, Moon-Yong Kim2
Implementation of Video Mirroring System based on IP / 108	Seungwon Lee1, Soonchul Kwon 2, Seunghyun Lee 3
A new type of multimedia content with Chinese characters as the core——Barrage / 118	Yang Pan, KiHong Kim, JiHui Yan
Cloth Product Recognition based on Siamese Network with Body Region Extraction method / 128	Sutanto Edward Budiman†, Edwin Kurniawan††, Seung Heon Lee†, Jae Seung Lee†, and Suk-Ho Lee†††
Discussion about the Priority for the Improvement of Performer Training in Korea / 135	BongHee Son
The effect of Adversity Index Perceived by Organizational Members on Entrepreneurial Orientation and Organizational Learning Competency / 142	Moon Jun Kim*, Su Hee Kim**
■ Bio or medical Information Technology (BIT) Research on the Coupling Coordination Relationship between Regional Information Technology Level and Economic Development / 153	Jin-yang Li1, Hyung-Ho kim2, Jun-Won Yang3
Effects of Nursing Skills Educational Programs Using Multimedia / 163	Keum-Bong Choi
A Study on Sustainable Development Efficiency of Foreign Trade in Western China Based on DEA Model / 171	Yan Xu, Jae-yeon Sim
Comparison of Performance According to Preprocessing Methods in Estimating %IMF of Hanwoo Using CNN in Ultrasound Images / 185	Sang Hyun, Kim
The Effect of Problem-Based Learning for Patient Safety on Self-Leadership, Patient Safety Competencies, and Reflective Thinking of Nursing Students / 194	Jung-Ha Park, Ji-Ah Yun, Kyoung-Duck Park
■ Environmental Information Technology (EIT) A Tight Upper Bound on Capacity of Intelligent Reflecting Surface Transmissions Towards 6G Networks / 205	Kyuhyuk Chung
Data-Based Monitoring System for Smart Kitchen Farm / 211	Ye Dong Yoon, Woo Sung Jang, So Young Moon, *R. Young Chul Kim
A Study on the Steering System of Electric Scooter / 219	Sung Cheon Park



The Institute of Internet, Broadcasting and Communication

# International Journal of Advanced Smart Convergence

International Journal of Advanced Smart Convergence

Volume 11 Number 2, June 2022

The Institute of Internet, Broadcasting and Communication



# IJASC

 The Institute of Internet, Broadcasting and Communication

<http://www.iibc.kr>



## The Board of Directors

### Administrative Committee

#### Advisory Board

Edward J. Rothwell	(Michigan State University, USA)
Eric T. Matson	(Purdue University, USA)
Dong Man Lee	(Korea Advanced Institute of Science and Technology, Korea)
Phan Ngoc Son	(Dong Nai Technology University, Vietnam)
Lei Li	(Hosei University, Japan)
Ram Bilas Pachori	(Indian Institute of Technology Indore, India)

#### President of IIBC & General Chair of IJASC Board

Jeong-Jin Kang (Dong Seoul University, Korea)

#### Editorial Board

##### Editor-in-Chief

In-Soo Koo (University of Ulsan, Korea)

##### Editorial Board

Byungjoo Park	(Hannam University, Korea)	Chan-Woo Moon	(Kookmin University, Korea)
Hyokyung Bahn	(Ewha University, Korea)	Jong-Wook Jang	(Dong-eui University, Korea)
Sangwon Lee	(Wonkwang University, Korea)	Jeong-Woo Jwa	(Jeju National University, Korea)
Jiook Cha	(Seoul National University, Korea)	Kyedong Jung	(Kwangwoon University, Korea)
Jung-Lae Kim	(Eulji University, Korea)	You-Sik Hong	(Sangji University, Korea)

#### International Editorial Board & Reviewers

Afshin S. Daryoush (Drexel University, USA)	Ju-Young Kim (Seoul National University Hospital, Korea)
Ahmad Hoorfar (Vilanova University, USA)	Kiyotoshi Yasumoto (Kyushu University, Japan)
Byeong-Kwon Ju (Korea University, Korea)	Ki-Young Lee (Eulji University, Korea)
Byung-Cheol Min (Purdue University, USA)	Koki Watanabe (Fukuoka Institute of Technology, Japan)
Christopher Davis (University of Maryland, USA)	Kwai-Man Luk (University of Hong Kong, Hong Kong)
Cynthia M. Furse (University of Utah, USA)	Malrey Lee (Chonbuk National University, Korea)
Dae-Ki Kang (Dongseo University, Korea)	Ming Yuchi (Hwazhong University of Science and Technology, China)
David Thiel (University of Griffith, Australia)	Mohammed N. Afsar (Tufts University, USA)
Dongcheul Lee (Hannam University, Korea)	MyeongBok Choi (Gangnung-Wonju National University, Korea)
Dong-Joon Lee (Korea Research Institute of Standards and Science, Korea)	Nguyen Ha Nam (Vietnam National University, Vietnam)
Erdenebaatar Altangerel (Mongolian University of S&T, Mongolia)	No-Jeong Heo (Dongyang University, Korea)
Ferdinant Mkrtchyan (Russian Academy of Sciences, Russia)	Ogtonbayar Bataa (Mongolian University of Science and Technology, Mongolia)
Gianluca Lazzi (NC State University, USA)	Quirino Balzano (University of Maryland, USA)
Gi-Hwan Kim (Semyeong University, Korea)	Raj Mittra (Pennsylvania State University, USA)
Haniph. Latchman (University of Florida, USA)	Ravi Sankar (University of South Florida, USA)
Heidar Malki (University of Houston, USA)	Rethina Kumar (Bharathidasan University, India)
Hongqiang Zhai (Philips Research North America, USA)	Roslin John Robles (University of San Agustin, Philippines)
Hyung-Yun Kong (Ulsan University, Korea)	Safieddin Safavi-Naeini (University of Waterloo, Canada)
Il-Kyoo Lee (Kongju National University, Korea)	Song K. Choi (University of Hawaii, USA)
Jaime Fonseca (Minho University, Portugal)	Suheet K. Chaudhuri (University of Waterloo, Canada)
Jeong-lae Kim (Eulji University, Korea)	Tetsuo Kinoshita (Tohoku University, Japan)
Jie Bao (Samsung Information System America, USA)	Vakhtang Jandieri (Kyungpook National University, Korea)
Jin-Young Kim (Kwangwoon University, Korea)	YangHao (University of London, UK)
Jong Pil Jeong (Sung KyunKwan University, Korea)	Yeong Min Jang (Kookmin University, Korea)
Jong-Hoon Yun (University of Nebraska at Omaha, USA)	Yiannis Vardaxoglou (Loughborough University, UK)
Jong-Jin Park (Chungwoon University, Korea)	Yong-Kap Kim (Wonkwang University, Korea)
Joshua R. Smith (University of Washington, USA)	Yoonsik Choe (Yonsei University, Korea)
Jun Jo (Griffith University, Australia)	Yu Ju Lin (Charleston Southern University, USA)

#### Manuscript Editor

Sung-Hee Ju (IIBC, Korea)

## Subscriptions

The International Journal of Advanced Smart Convergence (IJASC) is an international interdisciplinary four times a year journal published by the Institute of Internet, Broadcasting and Communication.

All correspondence related to the subscription should be addressed to the head office of the Institute (Korea).

## Head Office

The Institute of Internet, Broadcasting and Communication (IIBC)

#610, 101 Jungdae-ro  
Songpa-Gu, Seoul, 05719 Korea  
Tel: +82-2-407-7718  
Fax: +82-2-407-7716  
E-mail: iibc@iibc.kr  
Homepage: www.iibc.kr

## Printing office

Knowledge Forest Company  
502, 260, Songpa-daero, Songpa-gu,  
Seoul, Republic of Korea  
Tel: +82-2-407-7710  
Fax: +82-2-407-7740  
E-mail: k-f@k-f.kr  
Homepage: www.k-f.kr

This Journal is supported by the Korean Federation of Science and Technology Societies Grant funded by the Korean Government (MEST).

This journal is indexed in KCI and published by following the policy of Thomson Reuters, Elsevier in order to register for Science Citation Index Expanded (SCIE) and Scopus.

©2022 The Institute of Internet, Broadcasting and Communication (IIBC)

## Table of Contents

### ■ Telecommunication Information Technology (TIT)

**CPC: A File I/O Cache Management Policy for Compute-Bound Workloads / 01**

*Hyokyung Bahn*

**Autonomous Vehicles as Safety and Security Agents in Real-Life Environments / 07**

*Ahmed Abdulhakim Al-Absi\**

### ■ Human-Machine Interaction Technology (HIT)

**Joint Demosaicing and Super-resolution of Color Filter Array Image based on Deep Image Prior Network / 13**

*Edwin Kurniawan† and Suk-Ho Lee††*

**Fundamental Function Design of Real-Time Unmanned Monitoring System Applying YOLOv5s on NVIDIA TX2TM AI Edge Computing Platform / 22**

*SI HYUN LEE*

**Prediction of changes in fine dust concentration using LSTM model / 30**

*Gi-Seok Lee\*, Sang-Hyun Lee\*\**

**A study of creative human judgment through the application of machine learning algorithms and feature selection algorithms / 38**

*Yong Jun Kim\*, Jung Min Park\*\**

### ■ Nano Information Technology (NIT)

**An Integrated Model for Investigating the Impacts of Telepresence on Cultural Heritage Attachment in Virtual Museum / 44**

*Kyung-Wan Hong, Ph.D.1, Hyeon-Cheol Kim, Ph.D.2†*

**W-band Frequency Synthesizer Development Based on Interposer Technology Using MMIC Chip Design and Fabrication Results / 53**

*Wansik Kim, Hwanyong Yeo, Juyoung Lee, Young-Gon Kim, Mihui Seo, Sosu Kim*

**Study of Implementation of Broadband Antireflection Coating for Luminescent Solar Concentrators to Optimized the Efficiency / 59**

*Song Ngo Duy*

### ■ Culture Information Technology (CIT)

**Comparison of the Characteristics of Green Screen and LED Wall in Virtual Production System / 64**

*Xinyi Shan1, Jeanhun Chung\**

**A study on the applicability of interactive technology in VR video content production / 71**

*Miaoyihai Liu1, Jeanhun Chung\**

**Research of Character Design in Side-scrolling Horror Puzzle Games / 77**

*Qi Yi, Jeanhun Chung\**

**Research of popular success factors of game content <Genshin Impact> / 83**

*Miaoyihai Liu1, Jeanhun Chung\**

**A study on the expansibility of sound-responsive visual art contents / 88**

*Qianqian Jiang1, Jean-Hun Chung2*

- A Study on Influencer Food-Content Sentiment Keyword Analysis using Semantic Network based on Social Network / 95**  
*Gi-Hwan Ryu\**, *Chaelin Yu\*\**, *Jun Young Lee \*\*\**, *Seok-Jae Moon\*\*\*\**
- Smart Home Systems for Safety and Security and Individuals' Motivational Orientation to Prevention / 102**  
*Heayon Cho1*, *Moon-Yong Kim2*
- Implementation of Video Mirroring System based on IP / 108**  
*Seungwon Lee1*, *Soonchul Kwon 2*, *Seunghyun Lee 3*
- A new type of multimedia content with Chinese characters as the core——Barrage / 118**  
*Yang Pan*, *KiHong Kim*, *JiHui Yan*
- Cloth Product Recognition based on Siamese Network with Body Region Extraction method / 128**  
*Sutanto Edward Budiman†*, *Edwin Kurniawan††*, *Seung Heon Lee‡*, *Jae Seung Lee‡*, and *Suk-Ho Lee†††*
- Discussion about the Priority for the Improvement of Performer Training in Korea / 135**  
*BongHee Son*
- The effect of Adversity Index Perceived by Organizational Members on Entrepreneurial Orientation and Organizational Learning Competency / 142**  
*Moon Jun Kim\**, *Su Hee Kim\*\**
- **Bio or medical Information Technology (BIT)**  
**Research on the Coupling Coordination Relationship between Regional Information Technology Level and Economic Development / 153**  
*Jin-yang Li1*, *Hyung-Ho kim2*, *Jun-Won Yang3*
- Effects of Nursing Skills Educational Programs Using Multimedia / 163**  
*Keum-Bong Choi*
- A Study on Sustainable Development Efficiency of Foreign Trade in Western China Based on DEA Model / 171**  
*Yan Xu*, *Jae-yeon Sim*
- Comparison of Performance According to Preprocessing Methods in Estimating %IMF of Hanwoo Using CNN in Ultrasound Images / 185**  
*Sang Hyun, Kim*
- The Effect of Problem-Based Learning for Patient Safety on Self-Leadership, Patient Safety Competencies, and Reflective Thinking of Nursing Students /194**  
*Jung-Ha Park*, *Ji-Ah Yun*, *Kyoung-Duck Park*
- **Environmental Information Technology (EIT)**  
**A Tight Upper Bound on Capacity of Intelligent Reflecting Surface Transmissions Towards 6G Networks / 205**  
*Kyuhyuk Chung*
- Data-Based Monitoring System for Smart Kitchen Farm / 211**  
*Ye Dong Yoon*, *Woo Sung Jang*, *So Young Moon*, *\*R. Young Chul Kim*
- A Study on the Steering System of Electric Scooter / 219**  
*Sung Cheon Park*

## Data-Based Monitoring System for Smart Kitchen Farm

Ye Dong Yoon, Woo Sung Jang, So Young Moon, \*R. Young Chul Kim

*M.S, Department of Software and Communication Engineering, Hongik University, Korea  
Dr, Department of Software and Communication Engineering, Hongik University, Korea  
Post Dr, Department of Software and Communication Engineering, Hongik University, Korea  
\* Professor, Department of Software and Communication Engineering, Hongik University, Korea*

*E-mail {uriel2001, whit2, bob}@hongik.ac.kr  
{yedong}@mail.hongik.ac.kr*

### Abstract

*Pandemic situations such as COVID-19 can occur supply chain crisis. Under the supply chain crisis, delivering farm products from the farm to the city is also very challenging. Therefore it is essential to prepare food sufficiency people who live in a city. We firmly insist on food self-production/consumption systems in each home. However, since it is impossible to grow high-quality crops without expertise knowledge. Therefore expert system is essential to grow high-quality crops in home. To address this problem, we propose a smart kitchen farm as a data-based monitoring system and platform with ICT convergence technology. Our proposed approach 1) collects data and makes judgments based on expert knowledge for home users, 2) increases product quality of the smart kitchen farms by predicting abnormal/normal crops, and 3) controls each personal home cultivation environment through data-based monitoring within the smart central server. We expect people can cultivate high-quality crops in their kitchens through this system without expert knowledge about cultivation.*

**Keywords:** Data Based Decision Making, Plant Disease Detection, Expert System, Data Collection

### 1. Introduction

Under COVID-19 the England shows how a supply chain crisis can cause food insufficiency [1]. There are many countries exist which have a poor degree of food self-sufficiency. These countries can be in danger of hunger under a supply chain crisis [2]. To secure our food security, we insist on our system of making urban farming as Cuba did to create sustainable city life [3].

Recently, as ICT convergence technology spreads in rural start-ups for smart farms is increasing as one of the means to solve many pending issues in domestic agriculture [4]. The Rural Development Administration are developing a Korean smart greenhouse model with accumulated know-how and item cultivation conditions to suit the characteristics of domestic horticulture industry centered on small and medium-sized vinyl greenhouse es [5].

---

Manuscript Received: May. 27, 2022 / Revised: June. 4, 2022 / Accepted: June. 5, 2022  
Corresponding Author: bob@hongik.ac.kr  
Tel: +82-44-860-2477, Fax: +82-44-865-0460  
Professor, Department of Software and Communication Engineering, Hongik University, Korea

However, this model is limited to large-scale producers at the corporate or farm level. This cannot fulfill the requirements of smart kitchen farm users who aim for self-sufficiency after the COVID-19 crisis. The city householders never have experience to cultivate any crops. To solve this problem, we propose a data-based monitoring system with A.I to classify disease of plant. The proposed approach controls plant growth on local own devices with information collected through remote terminal devices (RTU).

## 2. Related Works

### 2.1 Heterogeneous Smart Farm Data Collection Based on Model Transformation Techniques

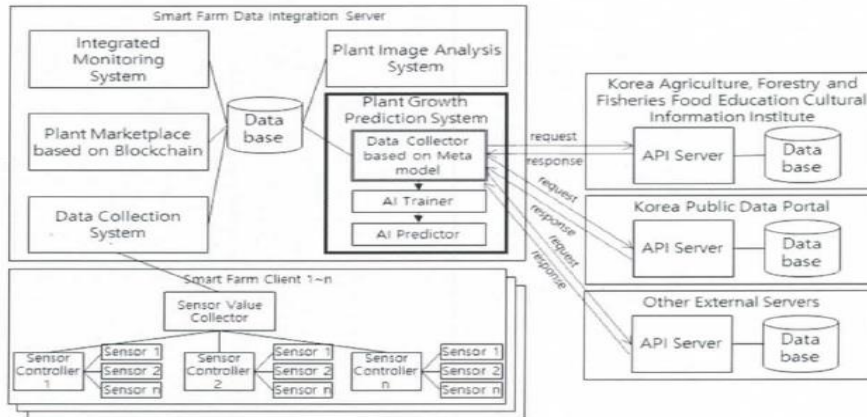

Figure 1. Heterogeneous smart farm data collection based on model conversion technique

Figure 1 shows a heterogeneous smart farm data collection method based on a model conversion technique [6]. Information such as public data, smart farm crop data, and environmental sensor data is integrated and processed and managed by applying meta-model-based model conversion techniques. Smart farm big data stored in heterogeneous databases can be automatically collected and made into AI learning data.

### 2.2 Convolutional Neural Network (CNN)

CNN is a convolutional neural network, a type of deep learning that can be learned while maintaining spatial information of an image [7]. Therefore, it is used to find patterns in images.

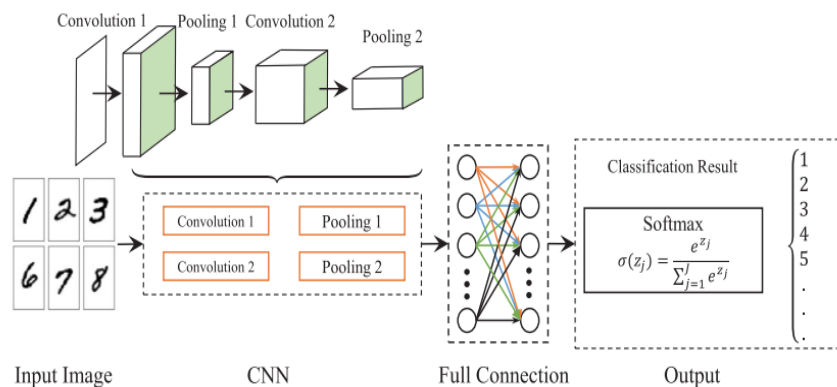

Figure 2. CNN model

Figure 2 shows the detailed process of CNN model. It is composed of several layers of convolution layer

and pooling layer to extract the characteristics of the image. The Convolution Layer is an essential element that reflects the activation function after applying a filter to the input data. The extracted feature classifies the image by entering the classification function through a fully connected layer for image classification. Since the characteristics of the image are extracted in the learning process, there is no need to create the characteristics for learning.

### 2.3 Hydroponics

Hydroponics is the way to grow crops without soil [8]. It can reduce water usage compared with conventional agriculture. Hydroponics have variable techniques. Each technique has common that roots of crop exposed to the culture solution.

LG Tiium is a representative commercially available kit of hydroponic system for home [9]. But it is not enough for home. Tiium is expensive, the number of crops that can be grown is limited and occur operating noise. Because The product uses a water pump to circulate culture solution

But our approach using a Fogponics. Fogponics supply aerosolized culture solution to root. Our approach using ultrasonic module to aerosolize the culture solution. It doesn't occur operating noise. Therefore, this approach is suitable for home

## 3. Our Data-Based Monitoring System for the Smart Kitchen Farm

### 3.1 Overall System Structure

Our system classifies the crop has disease or not and identify what the disease is. To classify it the system divided with central server and local devices. Local devices made with RTU to collect data and send it to central server and controller to control

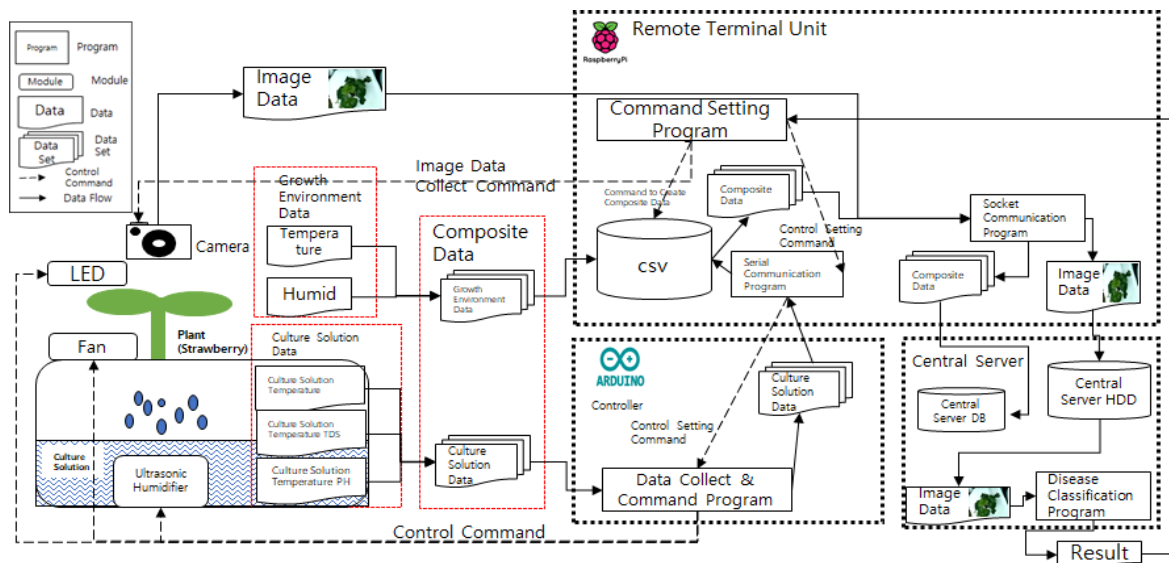

Figure 3. A Data-based monitoring system for smart kitchen farms

Figure 3 shows the overall structure of a data-based monitoring system for smart kitchen farms. Humid and Temperature data from sensor is stored in RTU. Images are sent to central server without stored in RTU. The RTU receive culture solution data from the Controller. The culture solution data transmitted from the controller

and the growth environment data collected by the RTU are combined and stored in the form of a file (\*.csv). The stored file is periodically delivered to the central server.

### 3.2 Deep Learning-Based Abnormal/Normal Crop Learning Method

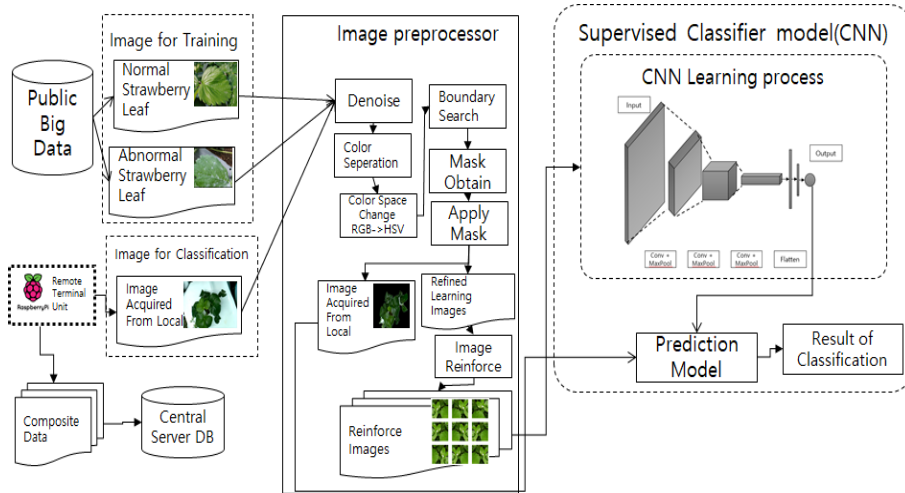

Figure 4. Abnormal/normal crop learning and classification

#### 3.2.1 Preprocessing crop images

The crop image preprocessing method is shown in the image preprocessing part of Figure 4. We preprocess image information in the central server. Preprocessed image use as inputs for a classifier. Then the classifier classifies whether there is a disease in the image and what kind of disease it has. Preprocessing is performed to improve the quality of the images. Central server Preprocess image before classify image or training A.I with images. Through preprocess images quality is enhanced for classification. Because after the preprocess image remove background which can cause noise for classify.

#### 3.2.2 CNN Learning for Abnormal/Normal Crop

Figure 4 is a CNN-based abnormal/normal crop learning method. Refined public data are trained on normal and abnormal leaves using CNN models. Create predictive models through learning. After purifying the image transmitted from the RTU, it is input into the prediction model to classify the disease status and type of the image.

	Before Pre-Process	After Pre-Process
Real life Image	Total norm image is 267 classifier correct is 22 True Positive is %f 8.239700374531834	Total norm image is 267 classifier correct is 48 True Positive is %f 17.97752808988764
Image for Verification	Total norm image is 694 classifier correct is 452 True Positive is %f 65.12968299711815	Total norm image is 188 classifier correct is 187 True Positive is %f 99.46808510638297

Figure 5. Classifier performance increases after preprocessing



Through this, the positive effect as shown in Figure 5 can be obtained. The accuracy of the classifier increases because only the parts that need to be classified remain.

The image file after purification is smaller in size than the original image data so that storage space may be efficiently used. The size of the smaller image data reduces the load of the central server by reducing the amount of computation required for classification.

In addition, the portion of the image excluding the region of interest is removed, reducing the likelihood of causing privacy infringement problems of data collected at home.

#### 4. A DATA-BASED MONITORING SYSTEM FOR HOME SMART FARMS

**The Remote Terminal Unit (RTU):** The RTU device uses Raspberry Pi4. RTU displays crop image to the user locally. The RTU communicates with both the central server and the controller. Data collected by the control unit is transmitted through serial communication with the control unit, an order is issued to the control unit, and is performed through socket communication. The data collected by the control unit and the RTU is transmitted to the central server and requests a judgment from the central server.

The RTU receives commands to be issued to the control unit through direct input from the user or communication with the central server and transmits them to the control unit. Temperature and humidity sensors (dht22) are attached to measure temperature and humidity inside the greenhouse, and webcams are connected to receive image data. An environment was prepared for pre-processing the image by covering it with a white cloth around the crop (strawberry).

**The Controller:** An Arduino is used as the controller. The controller receive command from connected RTU and control Led, Fan, Ultrasonic Humidifier. LED to control light for grow, fan for ventilation, and ultrasonic for supply nutrient to crop. The controller transmits data collected from sensors to the RTU. The sensors collect data from culture solution. Sensors collect culture solution temperature, TDS, and PH.

**The Central Server:** The central server receives and stores composite data and image transmitted from the RTU through socket communication. The composite data is stored in the central server DB, and the image data is stored as a file with the date and time of the received year as the name. Use Python, OpenCV libraries for image preprocessing. It uses the Tensorflow, Keras library for CNN learning. A.I was trained with public image data of strawberry from AI Hub [10] and Kaggle [11] to classify disease of leaves.

**The Crop Farming environment:**

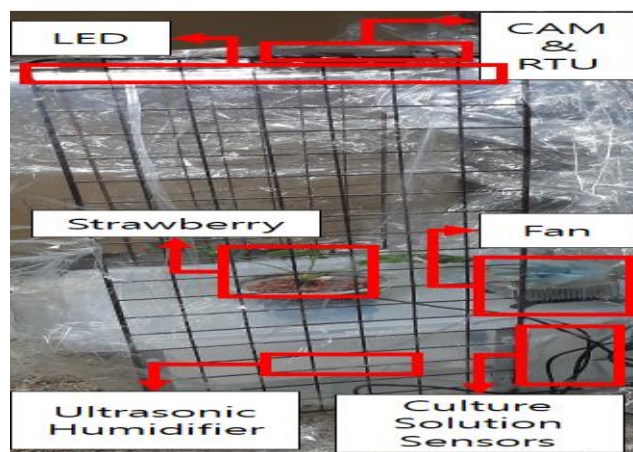

**Figure 6. Implemented crop cultivation environment**

Figure 6 shows the implemented crop cultivation environment. Vinyl was used to maintain a constant temperature and humidity.

**Our Smart Kitchen Farm System:** It is a data-based monitoring system for smart kitchen farm. RTU can show Real-time image of crop and collected environment data.



**Figure 7. Real-time crop monitoring**

Figure 7 shows an image acquired in real-time for a user.

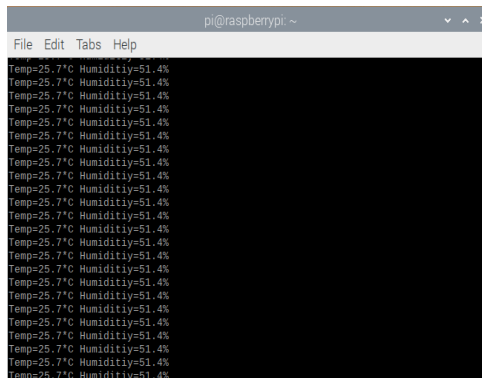

**Figure 8. Real-time environment data**

Figure 8 shows the sensor data acquired in real-time to the user.

## 5. RESULTS

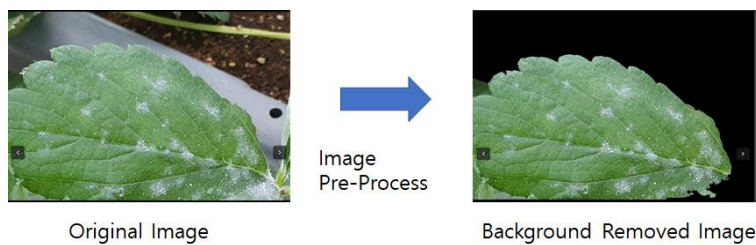

**Figure 9. Image preprocessing and results**

Figure 9 shows an image preprocessing result. The original image(left) was changed to a preprocessed

image(right).



**Figure 10. Normal crop image classified success**

Figure 10 shows a crop image classified normal. The pre-process was applied and classify image as normal leaf.



**Figure 11. Abnormal crop image classified success**

Figure 11 shows a preprocessed image classified have a disease. The pre-process was applied and classify image is powdery mildew.

## 6. CONCLUSION

We propose a monitoring system for smart kitchen farms. The system 1) makes judgments and collects data based on expertise for home users, 2) increases the productivity of smart kitchen farms by predicting abnormal/normal crops, and 3) performs data-based monitoring within the smart kitchen farm central server. The expert system to help make decisions is expected to help not only smart kitchen farm Users but also can help people who don't have expert knowledge such as farmer, gardener, and forestry workers. As a future study, we consider improving the accuracy of disease classification by improving the learning model of the central server and expanding functions such as pest detection and growth disorder analysis in the video. Also,

we consider making our systems can cultivate high-value crops such as herb or medicinal crops to help people who need the crop regularly.

## Acknowledgement

This work was supported by the Ministry of Education and the Korea Research Foundation (F21YY8102068) and the government (Ministry of Education) with the support of the Korea Research Foundation (No. 2021R1I1A305040711, No. 2021R1I1A1A01044060) in 2022

## References

- [1] Do Q. N., Mishra N., Wulandhari N. B. I., Ramudhin A., Sivarajah U., and Milligan G., "Supply chain agility responding to unprecedented changes: empirical evidence from the UK food supply chain during COVID-19 crisis," *Supply Chain Management*, Vol. 26, No. 6, pp. 737-752, 2021. DOI: <https://doi.org/10.1108/SCM-09-2020-0470>
- [2] Jeon Younghyeon, and Byeong-il Ahn, "Effects of a Tariff Reduction on Grain Self-Sufficiency: Evidence from Country-Level Panel Data," *Sustainability(MDPI)*, Vol. 9, No. 10: 1838, 2017. DOI: <https://doi.org/10.3390/su9101838>
- [3] Miguel A. Altieri, Nelso Companioni, Kristina Cañizares, Catherine Murphy, Peter Rosset, Martin Bourque, and Clara I. Nicholls. "The greening of the barrios: Urban agriculture for food security in Cuba," *Agriculture and Human Values*, Vol. 16, pp. 131–140, 1999. DOI: <https://doi.org/10.1023/A:1007545304561>
- [4] Yeo Uk-hyeon, In-bok Lee, Kyeong-seok Kwon, Taehwan Ha, Se-jun Park, Rack-woo Kim, and Sang-yeon Lee, "Analysis of Research Trend and Core Technologies Based on ICT to Materialize Smart-Farm," *Protected Horticulture and Plant Factory(The Korean Society for Bio-Environment Control)*, Vol. 25, No. 1, pp. 30-41, March 2016. DOI: <https://doi.org/10.12791/ksbec.2016.25.1.30>
- [5] Yun N. G., Lee J. S., Park G. S., and Lee J. Y., "Korean Smart Farm Policy and Technology development status," *Rural resources : Magazine of the Korean Society of Agricultural Engineers*, Vol.59, No 2, pp. 19-27, 2017.
- [6] Woo Sung Jang, Jang Hwan Kim, Chae Yun Seo, and R. Young Chul Kim, "The Collection Method of Heterogeneous Smart Farm Data Based on Model Transformation Technique for Human Computer Friendly Learning," *HCII: Culture and Computing. Design Thinking and Cultural Computing (Springer)*, Vol. 12795, pp. 418-431, July 2021. DOI: [https://doi.org/10.1007/978-3-030-77431-8\\_26](https://doi.org/10.1007/978-3-030-77431-8_26)
- [7] LEI Xinyu, PAN Hongguang, and HUANG Xiangdong, "A dilated CNN model for image classification," *IEEE Access*, Vol 7 pp. 124087-124095, 2019. DOI: <https://doi.org/10.1109/ACCESS.2019.2927169>
- [8] Falmata Modu, Adam Adam, Farouq Aliyu, Audu Mabu, and Mahdi Musa. "A Survey of Smart Hydroponic Systems," *Advances in Science, Technology and Engineering Systems Journal*. Vol. 5, pp. 233-248, 2020. DOI: <https://doi.org/10.25046/aj050130>
- [9] LG, Tiiun, <https://www.lge.co.kr/lg-tiiun>.
- [10] NIA, Ai hub, <https://aihub.or.kr/>.
- [11] Alphabet Inc, Kaggle, <https://www.kaggle.com/>.